

REFERENCE ONLY

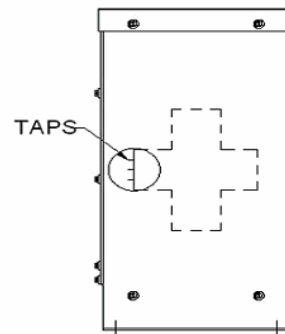
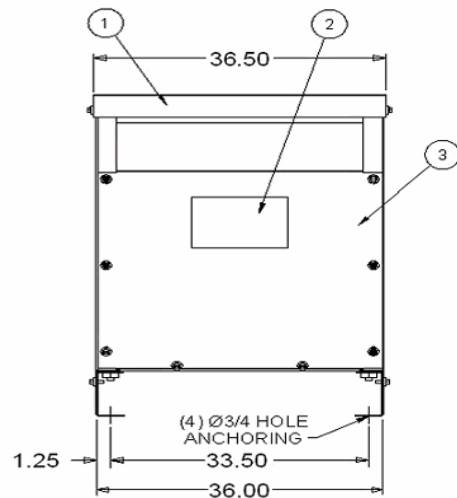
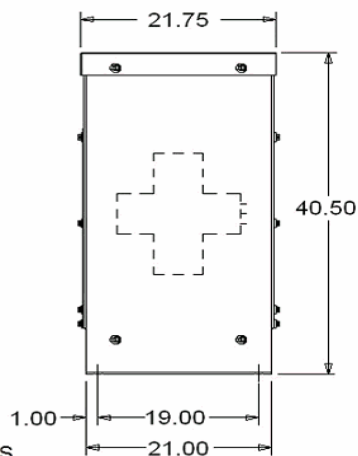

Parts List		
ITEM	QTY	DESCRIPTION
1	1	TOP COVER - REMOVABLE
2	1	DIAGRAMATIC NAMEPLATE
3	2	FRONT & REAR PANEL - REMOVABLE

NOTES

- 1) THIS DRAWING IS NOT FOR CONSTRUCTION PURPOSES. VERIFY WITH FACTORY BEFORE CONSTRUCTION.
- 2) TRANSFORMERS ARE MANUFACTURED AND TESTED PER APPLICABLE ANSI, NEMA AND IEEE STANDARDS.
- 3) UNLESS OTHERWISE SPECIFIED, ALL DIMENSIONS ARE IN INCHES WITH +/- 1/4" TOLERANCE.
- 4) TRANSFORMER IS U.L. & C.S.A. LISTED AND LABELED.
- 5) UNIT IS DESIGNED FOR INDOOR (NEMA1) AND OUTDOOR (NEMA3R) APPLICATION.

WQ17763 Item #1 Specifications	
Cust Tag #	-
KVA	150
Primary Volts	240 D
Primary Conn	Delta
Secondary Volts	208Y/120
Secondary Conn	Wye
Taps	Standard
Phase	3
HZ	60
Temp Rise	150
Winding	Aluminum
K-Factor	K-1
Efficiency	DOE 2016
Sound Level	50
Enclosure	Indoor/Outdoor
Enclosure Matl	HRPO (STD)
Totl Enclosed	0
Color	ANSI 61 (STD)
Approx. Weight	999
Elect. Shield	0
HT150C3B2-D16	



MGM TRANSFORMER CO.
 5701 Smithway
 Commerce, CA 90040 (800) 423-4366

600V GENERAL PURPOSE DRY TYPE
TRANSFORMER OUTLINE, CASE GPC+ (CASE 5)