

REFERENCE
ONLY

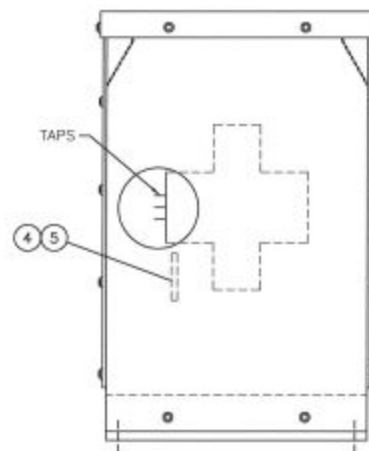

| LEGEND | | |
|--------|-----|--------------------------------|
| ITEM | QTY | DESCRIPTIONS |
| 1 | 1 | TOP COVER - REMOVABLE |
| 2 | 1 | DIAGRAMATIC NAMEPLATE |
| 3 | 2 | FRONT & REAR PANEL - REMOVABLE |
| 4 | 3 | HV TERMINAL |
| 5 | 4 | LV TERMINAL |

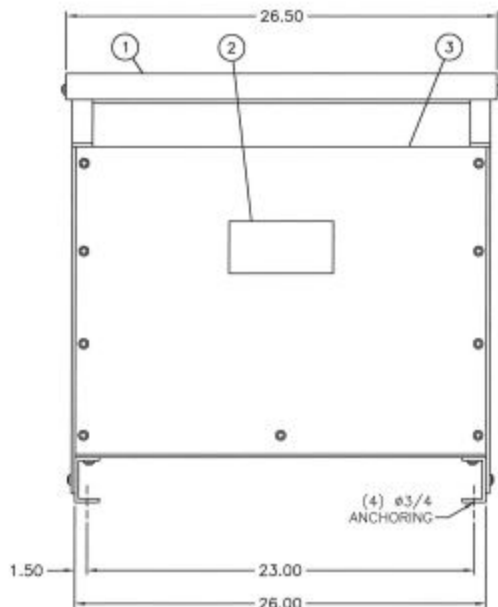
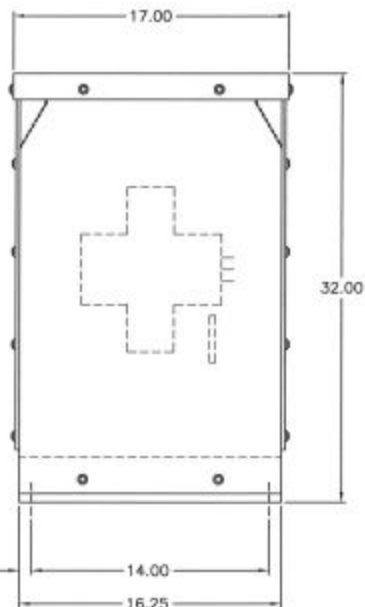

HT45A3B1-D16

| | |
|---|--|
| S.O. NO: | DWG FOR: <input checked="" type="checkbox"/> RECORD <input type="checkbox"/> APPROVAL <input type="checkbox"/> QUOTE |
| CUST/JOB NAME: | - |
| CUST ORDER NO.: | - |
| SERIAL NO.: | - |
| ID TAG: | - |
| KVA: 45 HIGH VOLTAGE: 480 DELTA LOW VOLTAGE: 208Y/120 HV TAPS: 2A4B @ 2 1/2% HV-KV BIL: 10 LV-KV BIL: 10 PHASE: 3 FREQ-HZ: 60 TEMP RISE-°C: 150 COOLING CLASS: AA INSULATION CLASS: 220°C WINDING COND: COPPER PAINT/COATING: ANSI 61 GRAY APPRX WT-LBS/KGS: 455/207 | |
| <input type="checkbox"/> STANDARD <input checked="" type="checkbox"/> DOE 10CFR <input type="checkbox"/> K1 <input type="checkbox"/> K4 <input type="checkbox"/> K13 <input type="checkbox"/> K20 | |

- NOTES:**
- 1) TRANSFORMERS ARE MANUFACTURED AND TESTED PER APPLICABLE ANSI, NEMA AND IEEE STDS, LATEST REVISION.
 - 2) UNLESS OTHERWISE SPECIFIED, ALL DIMENSIONS ARE IN INCHES WITH ± 1/4" TOLERANCE.
 - 3) TRANSFORMER IS UL & CUL LISTED AND LABELED.
 - 4) MEETS DOE 10CFR 431, 2016 EFFICIENCY - 45 KVA TRANSFORMER MEET OR EXCEED EFFICIENCY = 98.40% @75°C@35% LOAD.
 - 5) TRANSFORMER DESIGNED FOR INDOOR (NEMA 1) AND OUTDOOR (NEMA 3R) APPLICATION.
 - 6) TRANSFORMER NOT TO BE INSTALLED IN PUBLIC ACCESS AREAS OTHERWISE IT MUST BE FENCED OR ISOLATED.

| | | | |
|-----------------|----------------|--|---|
| PAGE 1 OF 1 | SCALE: NONE | TITLE: TRANSFORMER OUTLINE DRY TYPE GENERAL PURPOSE, CASE B | <input checked="" type="checkbox"/> OUTDOOR <input type="checkbox"/> INDOOR |
| BY: | DATE: 02/16/17 | MGM TRANSFORMER CO. <small>CITY OF COMMERCE, CALIFORNIA TEL: (262) 722-0886, FAX: (262) 722-8182</small> | CAD NO. MG00045N3-16-45YSC |
| CADD: HM | DATE: 02/16/17 | | REV. |
| CHKD: AH | DATE: 02/16/17 | | |
| APPD: <i>AH</i> | DATE: 2/22/17 | | |
| REVISIONS | | | |