

CONDUIT SPACE
(BOTTOM)

REFERENCE ONLY

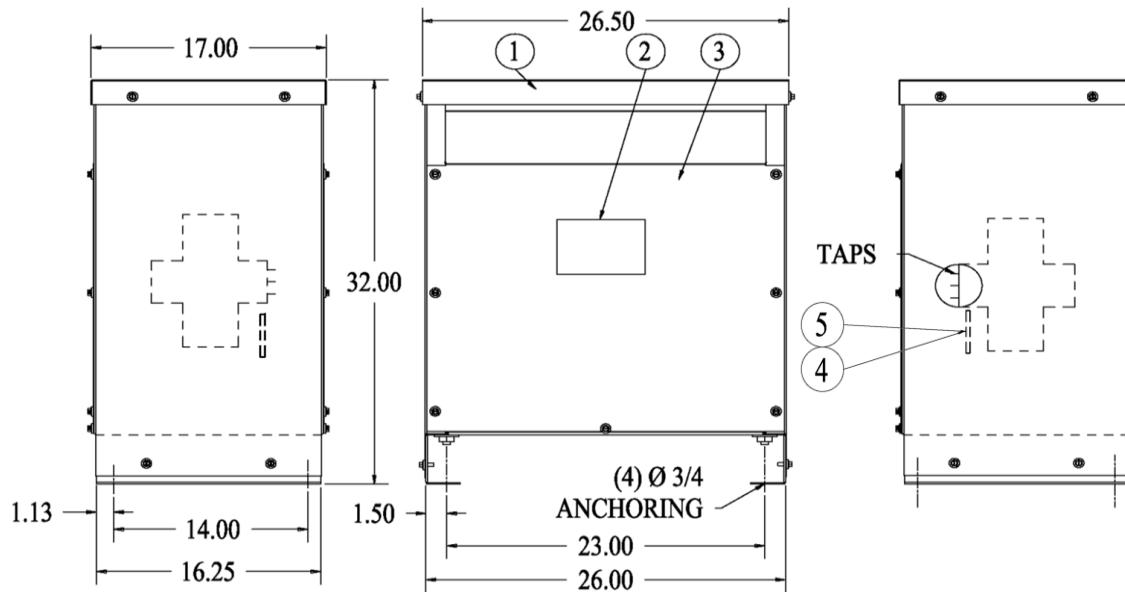

- NOTES: 1) THIS DRAWING IS NOT FOR CONSTRUCTION PURPOSES. VERIFY WITH FACTORY BEFORE CONSTRUCTION.
 2) TRANSFORMERS ARE MANUFACTURED AND TESTED PER APPLICABLE ANSI, NEMA, AND IEEE STANDARDS.
 3) UNLESS OTHERWISE SPECIFIED ALL DIMENSIONS ARE IN INCHES WITH ± 1/4" TOLERANCE.
 4) TRANSFORMER IS UL & CSA LISTED AND LABELED.
 5) UNIT IS DESIGNED FOR INDOOR (NEMA1) AND OUTDOOR (NEMA3R) APPLICATION.

Parts List		
ITEM	QTY	DESCRIPTION
1	1	TOP COVER - REMOVABLE
2	1	DIAGRAMATIC NAMEPLATE
3	2	FRONT & REAR PANEL - REMOVABLE
4	4	HV TERMINAL
5	3	LV TERMINAL



HT45G3D2-16

S.O. NO:
 DWG FOR: RECORD APPROVAL QUOTE

CUST/JOB NAME:
 CUST ORDER NO:
 SERIAL NO:
 ID TAG:

KVA: 45
 HIGH VOLTAGE: 480Y/277
 LOW VOLTAGE: 208D (PRIMARY)
 HV TAPS: 2A4B 2 1/2 %
 HV-KV BIL: 10
 LV-KV BIL: 10
 PHASE: SINGLE THREE
 FREQ-HZ: 60 50
 TEMP RISE - °C: 150 115 80
 COOLING CLASS: AA
 WINDING COND: ALUMINUM COPPER
 PAINT/COATING: ANSI 61 LIGHT GRAY
 APPRX WT - LBS: 400

STANDARD DOE 2016 K4 K13 K20

	SCALE : N/A	PAGE 1 OF 1
	CADD:	
	CHKD:	
	APPD:	
REVISIONS		

3PH, 600V GENERAL PURPOSE DRY TYPE
 TRANSFORMER OUTLINE, CASE B (CASE 2)

MGM TRANSFORMER CO.
 CITY OF COMMERCE, CALIFORNIA
 TEL: (323) 726-0888, FAX: (323) 726-8192

CAD NO. **REV:**